

NEW CRITICAL INSTRUCTIONS. MUST READ!



HHX Ride-On Trowel

Cross Shaft and Drive Pulley Installation Instructions

The following instructions are intended to assist the user in the installation of a cross shaft and/or drive pulley. Please read all instructions before installation.

REQUIRED TOOLS

- Hammer
- Torque Wrench
- 3/8 Ratchet
- 3/8, 7/16, 1/2, 3/4, 9/16, 5/8, 15/16, 13mm Sockets
- 3/16 and 1/4 Allen sockets
- Open/box-end wrenches
- Misc. Pry-Bars
- CV Joint Grease
- Grease Gun w/Multi-purpose grease
- 2x4 wood block
- Forklift/Hoist
- Clutch Puller
- Heavy Duty Jack Stands
- Scotch-brite Pad
- Brake Cleaner

PARTS

Verify that all parts are accounted for. See Figure 1 and Table 1.

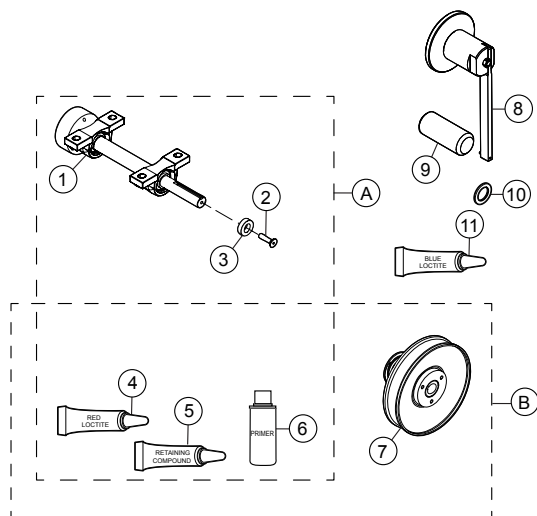

Figure 1. Cross Shaft and Drive Pulley Kits

Table 1. Parts Needed

| Item | Qty. | Part No. | Description | Remarks |
|------|------|-----------|--------------------------------------|--------------------|
| A | 1 | 30106 | Cross Shaft Assy Service Kit | Includes items 1-6 |
| B | 1 | 23363-2S | Pulley, Lower Assy | Includes items 4-7 |
| 1 | 1 | 30104 | Cross Shaft Assy | |
| 2 | 1 | 30107 | Screw, FHCS, 3/8-16 X 1.25 LH Thread | |
| 3 | 1 | 30110 | Spacer, CSK Ø1.375 Ø.391x.281 | |
| 4 | 1 | 19379-014 | Loctite™ 271 | Red |
| 5 | 1 | 32434 | Retaining Compound, Loctite™ 609 | |
| 6 | 1 | 32441 | Primer, Loctite™ 7649 | |
| 7 | 1 | 23363-2 | Pulley, Lower | |
| 8 | 1 | 23436 | Alignment Gauge | |
| 9 | 1 | 23415 | Sleeve, Alignment Gauge | |
| 10 | A/R | 11773 | Shims | .031 Thickness |
| 11 | 1 | 1477 | Loctite™ 242 | Blue |

WORK SAFELY!

Only a **qualified service technician** with proper training should perform this installation. Follow all shop safety rules when performing this installation.

LIFTING THE TROWEL

1. Send a lifting strap or chain through the lift points on each side of the trowel. Attach the ends of the lifting strap or chain to the lifting device (Figure 2).

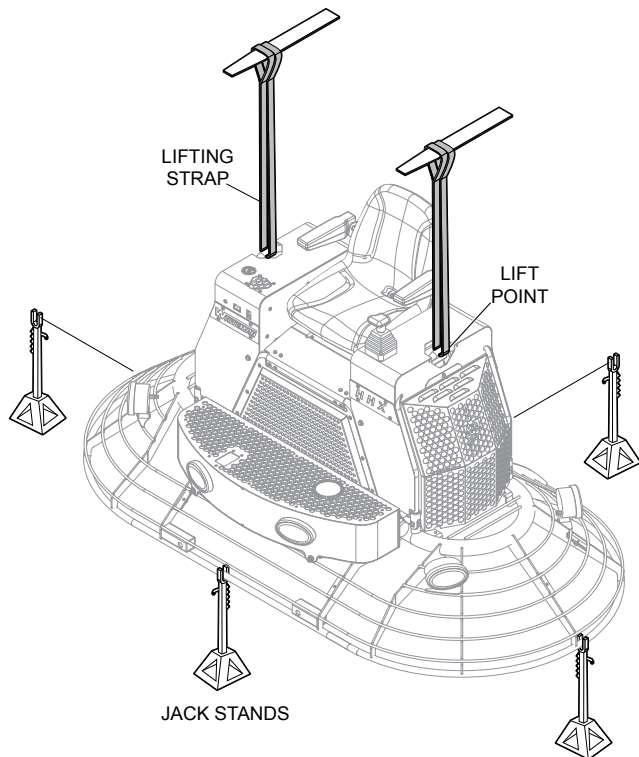

Figure 2. Lifting the Trowel

2. Next, place the trowel on heavy duty jack stands.

CAUTION

Trowel blades are sharp. Keep clear of blades while performing procedure. It is recommended that trowel blades are removed to prevent injury.

SIDE GUARD REMOVAL

1. Remove side guards from left and right seat frame assemblies. See Figure 3.

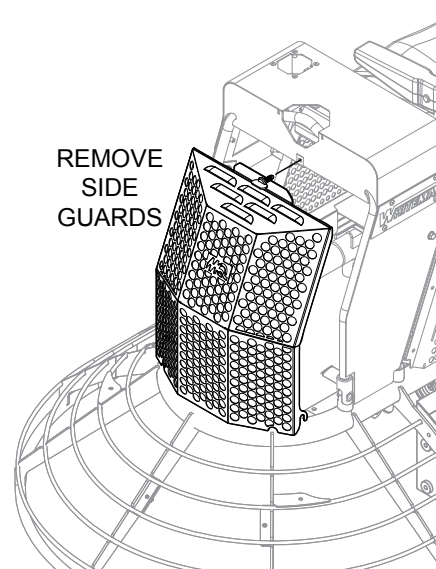

Figure 3. Remove Side Guards

BATTERY REMOVAL

Reference Figure 4.

1. Disconnect battery cables from the battery.
2. Remove battery from battery plate. Set aside in a clean, safe place.

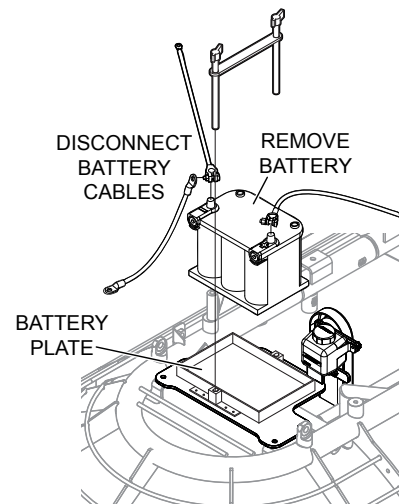

Figure 4. Battery and Spare Belt Removal

SEAT FRAME ROTATION/REAR PANEL REMOVAL

Refer to Figure 5.

1. Use a 14mm socket to remove the 2 bolts that secure the left seat frame to the rear engine panel. Set bolts aside for later use.
2. Rotate the left side seat frame to the horizontal position.
3. Remove side panel on right seat frame.
4. Repeat steps 1 and 2 for right side seat frame assembly.
5. Rotate seat to vertical position.
6. Cut cable tie that secures choke cable to rear engine panel.
7. Loosen clamp around air intake hose.
8. Use a 16mm socket to remove the 2 bolts that secure the rear engine panel to the frame. Set bolts aside for later use.
9. Remove the rear engine panel and hardware. Set aside in a clean, safe place.

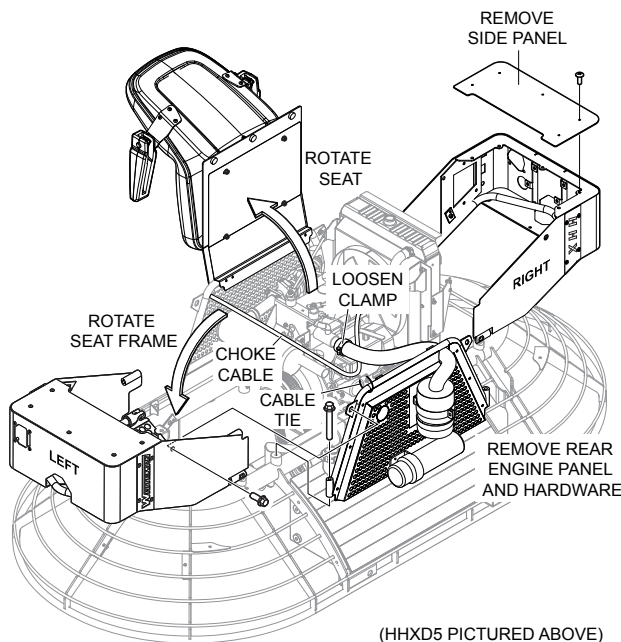

Figure 5. Frame Rotation and Rear Engine Panel Removal

SPLASH GUARD REMOVAL

NOTICE

If trowel blades have not been removed, they must be pitched flat in order to allow removal of splash pan.

1. Remove splash pan and hardware from trowel frame. Set aside in a clean, safe place. See Figure 6

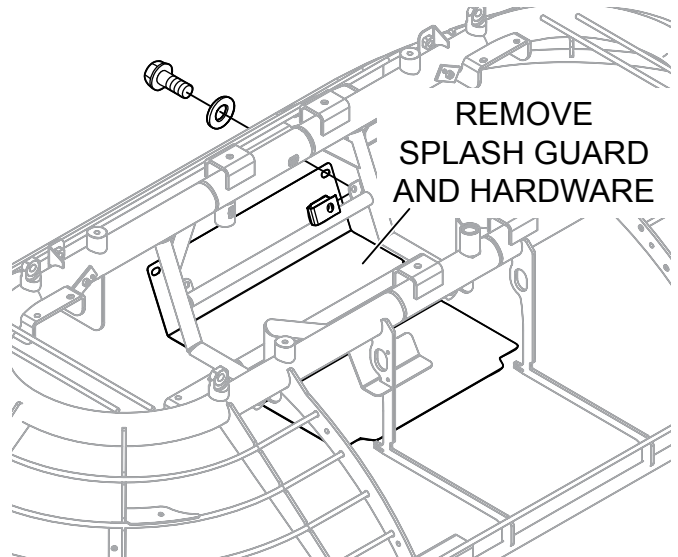

Figure 6. Remove Splash Guard

FUEL TANK REMOVAL

Refer to Figure 7.

1. Place fuel shut-off valve on fuel tank to the OFF position.
2. Disconnect fuel lines from the fuel tank. Clamp lines to prevent fuel spillage.

3. Disconnect electrical connection from the bottom of the fuel pump (HHXG5) or fuel filter (HHXD5).

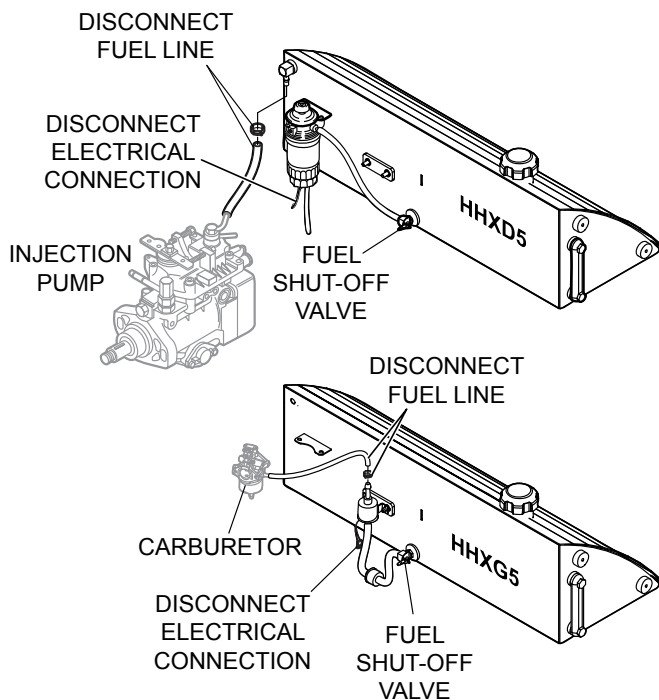

Figure 7. Disconnect Fuel Lines and Electrical Connections

4. Use a 13mm socket to remove the 4 bolts securing the fuel tank to the frame. Set aside for later use. See Figure 8.
5. If desired, fuel tank may be drained to make lifting from the trowel easier.
6. Remove fuel tank from frame. Set fuel tank aside in a clean safe place.

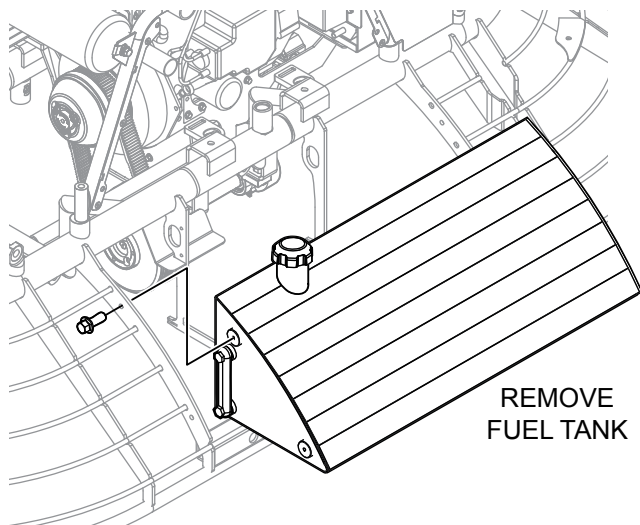

Figure 8. Fuel Tank Removal

CV AXLE ASSEMBLY (LEFT-SIDE) REMOVAL

NOTICE

Spider assemblies must be locked to the frame with chains in order to prevent clutch rotation.

Refer to Figure 9.

1. Starting at the left-side gearbox, use a 1/4" allen wrench to remove the 3 bolts that secure the CV axle to the left-side gearbox.
2. Next, use a 1/4" allen wrench to remove the 3 bolts that secure the CV axle to the lower drive pulley coupler.

NOTICE

Note that the 3 bolts securing the CV axle to the coupler are shorter than those securing the CV axle to the gearbox. Remember bolt orientation for reassembly.

3. Remove CV axle assembly. A mallet may be needed to dislodge the CV axle.

NOTICE

If using a mallet, **DO NOT** hit the CV axle with too much force. This could cause the ball bearings to become dislodged.

4. Set CV axle assembly and mounting hardware aside in a clean safe place.

CV AXLE ASSEMBLY (RIGHT-SIDE) REMOVAL

NOTICE

Disconnecting the right-side CV axle assembly from the gearbox is optional. Inspect rubber boots for damage or dirt. If CV axle is in good condition, it is not necessary to remove it from the gearbox. **Removal of the bolts securing CV axle to the cross shaft coupler is mandatory.**

Refer to Figure 9.

1. Remove the 3 bolts that secure the CV axle to the right-side gearbox (optional).
2. Remove the 3 bolts that secure the CV axle to the cross shaft coupler.
3. Remove CV axle assembly (optional). Set CV axle assembly and mounting hardware aside in a clean safe place.

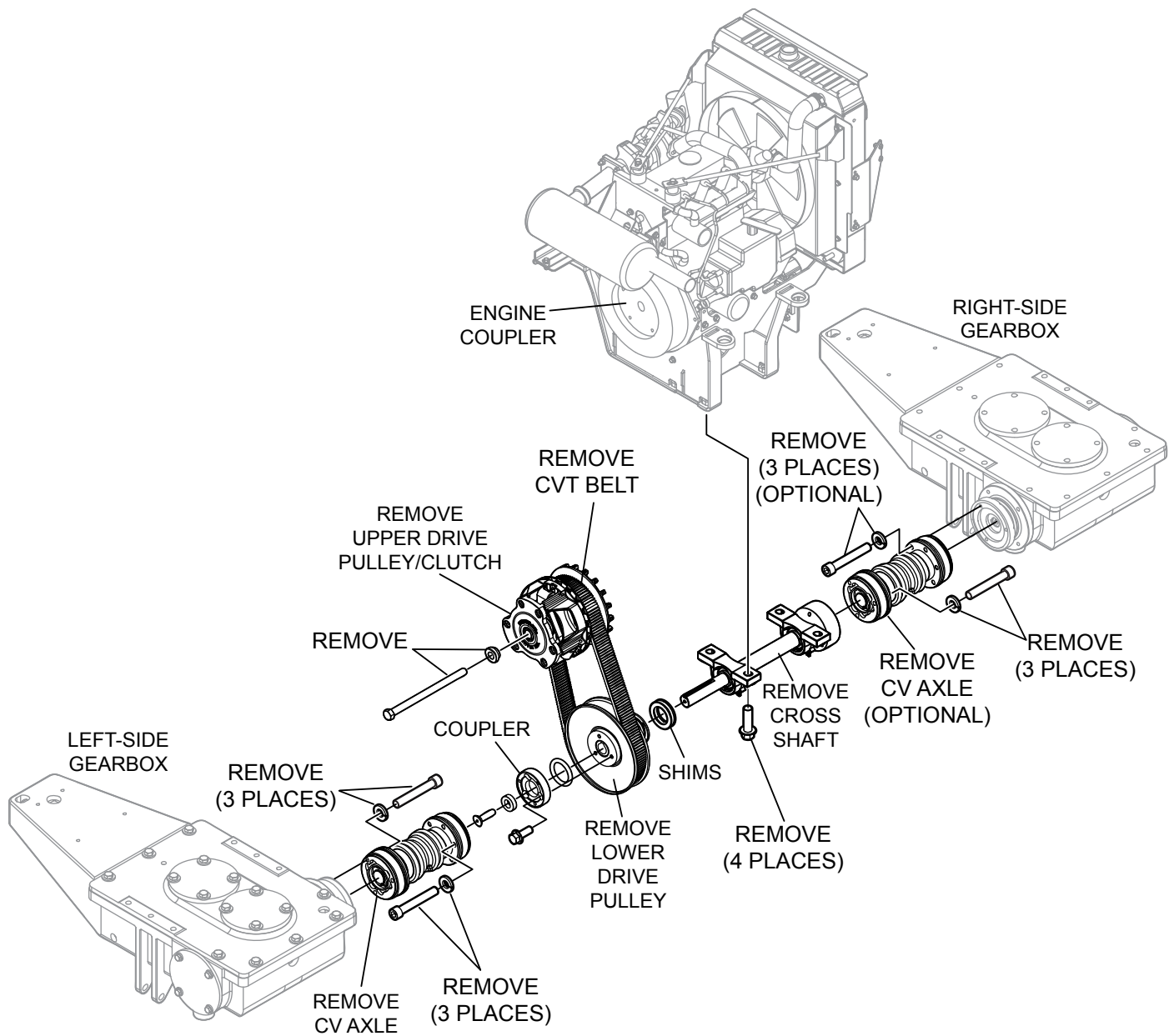

Figure 9. Drive Assembly Removal

UPPER CVT PULLEY REMOVAL

Refer to Figure 9.

1. Remove the clutch retaining screw and step washer that secure the clutch/pulley assembly to the engine shaft.
2. Pull clutch assembly off engine shaft. Puller tool (P/N 23155) may be required to remove clutch.

CROSS SHAFT/LOWER PULLEY REMOVAL

Refer to Figure 9.

1. Use a 16mm socket to remove the 4 bolts that secure the cross shaft bearing blocks to the engine cradle.
2. Remove cross shaft and lower pulley assembly. Discard item that will be replaced (either cross shaft or lower pulley or both, as required). Retain all other parts.

CROSS SHAFT/LOWER PULLEY INSTALLATION

NOTICE

The trowel frame bar on which the left hydraulic steering cylinder mounts prevents the lower pulley from sliding on and off the cross shaft when it is mounted to the engine cradle. Because the alignment of the cross shaft is critical to drive assembly operation, the following procedure will be necessary.

1. Mount the cross shaft to the engine cradle.
2. Mark left bearing block position on the bottom of the cradle.
3. Shim cross shaft to align with stub shaft.
4. Remove cross shaft.
5. Mount lower pulley onto cross shaft.
6. Use scribe marks on engine cradle to reinstall cross shaft (with lower pulley) into the same position it was in during shimming.

The following sections describe the above procedure in detail.

5. Torque cross shaft mounting screws to 50 ft-lbs (68 N·m).

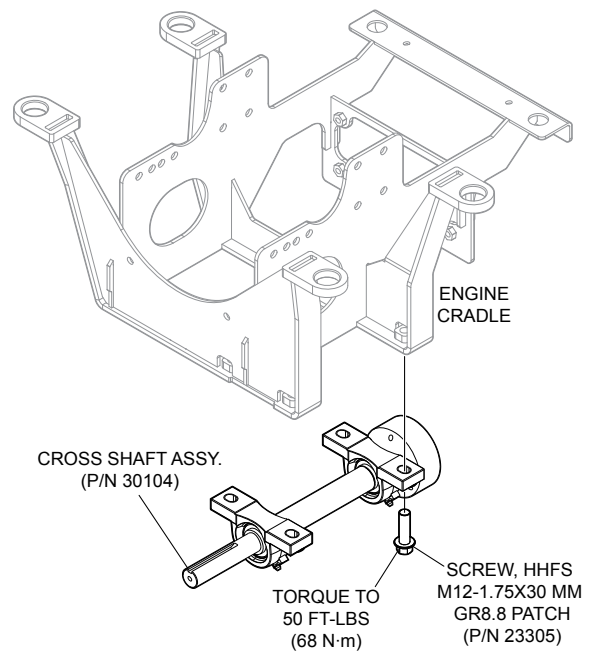

Figure 11. Cross Shaft Installation

Cross Shaft Mounting

1. Remove dust caps located on top of new cross shaft bearings (Figure 10).
2. Using a grease gun, grease both bearings. Use multi-purpose grade grease.
3. Reinstall dust cap to prevent contamination of the bearing.

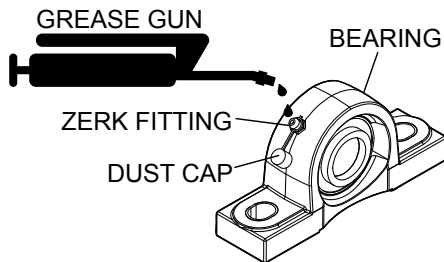

Figure 10. Bearing Lubrication

4. Use a 16mm socket to install **new** cross shaft assembly (Figure 11), P/N 30104, with existing screws (4), onto engine cradle. Apply Blue Loctite (P/N 1477).

Marking Cross Shaft Position

1. It is important to use a scribe to mark the edges of both bearing blocks on the bottom of the engine cradle. See Figure 12.

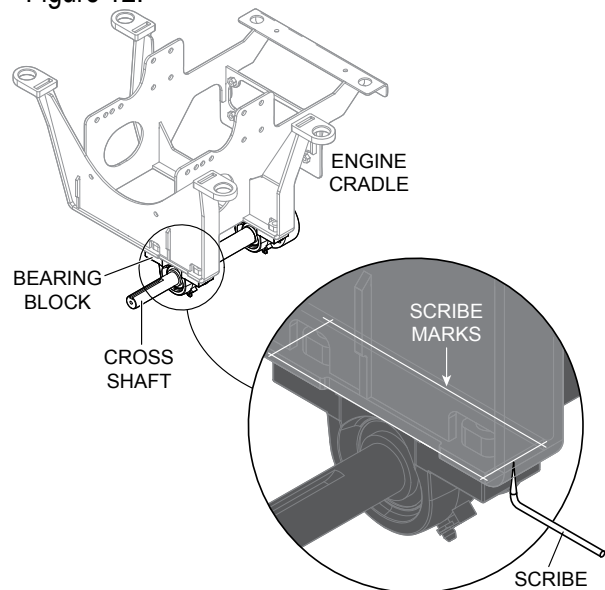

Figure 12. Cross Shaft Scribe Marks

Cross Shaft Alignment

See Figure 13.

1. Install gauge sleeve onto cross shaft.
2. Install gauge body onto stub shaft. Torque alignment bolt to 20 ft-lbs (27.1 N·m).
3. Measure the distance between the gauge pin and gauge sleeve with feeler gauge. This distance is an indication of the number of shims that will be required.

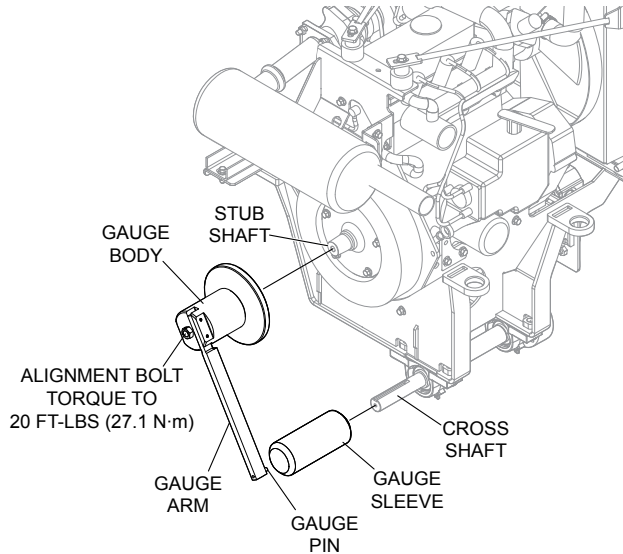

Figure 13. Cross Shaft Alignment

4. Rotate gauge arm and remove gauge sleeve. Install shims as required.
5. Reinstall gauge sleeve onto cross shaft. Insert .032" feeler gauge (Figure 14) between gauge pin and gauge sleeve.

NOTICE

The gauge sleeve must be held and pressed firmly against the cross shaft bearing when using feeler gauge to provide the most accurate measurement.

6. If .032" feeler gauge fits between gauge pin and gauge sleeve, re-shim until feeler gauge will not pass between gauge pin and gauge sleeve.

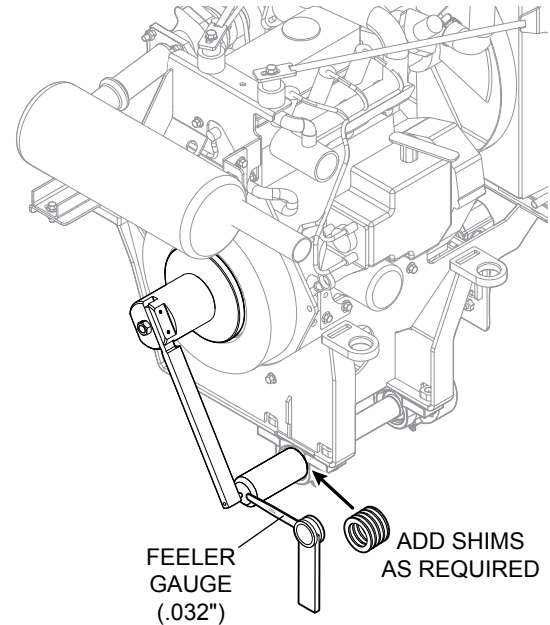

Figure 14. Shimming

Cross Shaft Removal

1. Unmount cross shaft using a 16mm socket while making sure to keep shims on shaft.

Lower Pulley Installation

Reference Figure 15.

1. Clean the cross shaft and lower pulley with brake cleaner.
2. Apply primer (Loctite 7649, P/N 32441) to the cross shaft and key way in the shaded area shown in Figure 15.
3. Using retaining compound (P/N 32434), apply to cross shaft and key way until coverage is complete with a minimum coating thickness of 1/16 of an inch.

4. Mount **new** lower pulley (P/N 23363-2) and key (P/N 20363) onto cross shaft.

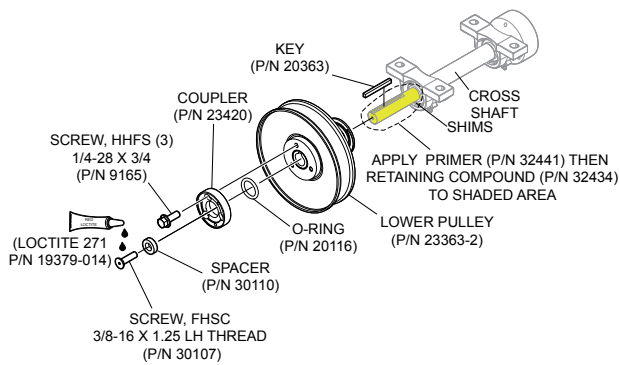

Figure 15. Lower Pulley Installation

5. Next, mount coupler (23420) onto lower pulley with O-ring (P/N 20116) placed between lower pulley and coupler.
6. Secure coupler with 1/4-28 x 3/4" screws (P/N 9165).
7. Clean the threads of 3/8-16 x1.25 LH thread retaining screw (P/N 30107) with brake cleaner. Apply primer (Loctite 7649, P/N 32441) then red loctite (P/N 19379-014) to the threads.
8. Insert 3/8-16 x1.25 LH thread retaining screw (P/N 30107) and spacer (P/N 30110) into cross shaft.

NOTICE

Mounting screws will not be torqued until after the Right-Side CV Axle Assembly is reinstalled/reconnected.

9. Once lower pulley has been mounted to shaft, wipe away any and all retaining compound.

NOTICE

It is extremely important that this unit **must not** be run for a period of at least 24 hours. The retaining compound needs to cross link and become completely cured during this time period.

Cross Shaft/Lower Pulley Installation

1. Remount cross shaft (with lower pulley assembly) onto engine cradle. Refer to "Cross Shaft Mounting" Section and Figure 11.

NOTICE

Make sure to align both bearing blocks with scribe marks on engine cradle. See Figure 12.

2. Place the CVT belt over the lower pulley. Do not attempt to squeeze the belt into the pulley groove yet.

CV AXLE REINSTALLATION / RECONNECTION

Before reinstalling the CV axle assemblies, ensure rubber boots are not cracked or worn (Figure 16). If boots are damaged, replace immediately. If CV axle assembly is dirty or covered with debris, clean with a mild soap or solvent. If necessary, grease CV axle as required.

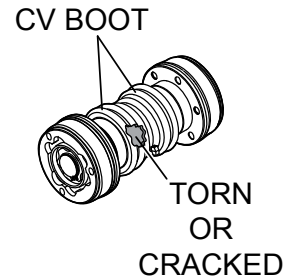

Figure 16. CV Boot Inspection

Right-Side CV Axle

1. Apply a thin coat of RTV silicone (Figure 17) to mating surfaces of CV axle assembly

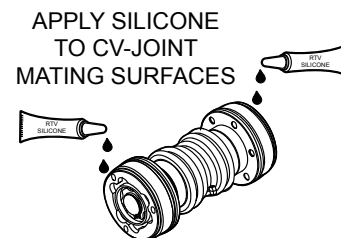

Figure 17. Applying RTV Silicone

2. Connect right-side CV axle assembly to right-side gearbox coupler (if applicable) and cross shaft coupler
3. Torque CV axle mounting screws to 12 ft-lbs.

NOTICE

Before connecting left-side CV axle assembly, torque lower pulley mounting screws. See "Lower Pulley Mounting Screw Torquing" Section.

Lower Pulley Mounting Screw Torquing

See Figure 18.

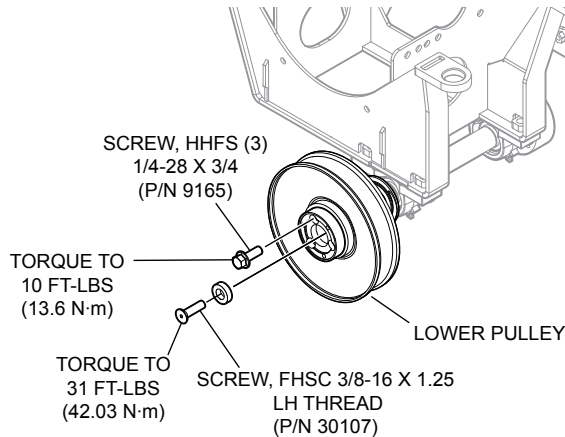

Figure 18. Lower Pulley Mounting Screw Torquing

1. Torque 1/4-28 x 3/4" screws (3) to 10 ft-lbs (13.6 N·m).
2. Torque 3/8-16 X 1.25" LH thread retaining screw to 31 ft-lbs (42.03 N·m).

Left-Side CV Axle

1. Apply a thin coat of RTV silicone (Figure 17) to mating surfaces of CV axle assembly.
2. Connect left-side CV axle assembly to left-side gearbox coupler and lower pulley.
3. Torque CV axle mounting screws to 12 ft-lbs.

PARTIAL REASSEMBLY / LOWERING TROWEL

The trowel must be lowered back to the ground prior to fully installing the belt and upper clutch. To gain access to lifting points, perform the following procedure. Refer to Figure 2 and Figure 5.

1. Reinstall rear engine panel with existing mounting bolts (2).
2. Rotate right-side seat frame back to vertical position and secure to rear engine panel with existing mounting bolts (2).
3. Rotate left-side seat frame back to vertical position. Temporarily secure to rear engine panel with existing mounting bolts. **DO NOT** over tighten, as left side seat frame will need to be rotated back to horizontal position after trowel is lowered to the ground.
4. Lower trowel onto the ground. Follow all heavy lifting safety precautions.
5. Once trowel is on the ground, remove left side mounting bolts and rotate left seat frame to horizontal position.

LOWER PULLEY BELT INSTALLATION

1. With the CVT belt placed over the lower pulley, squeeze the belt (Figure 19) and pull the belt upwards and towards the rear of the trowel. This will spread open the faces of the lower pulley.

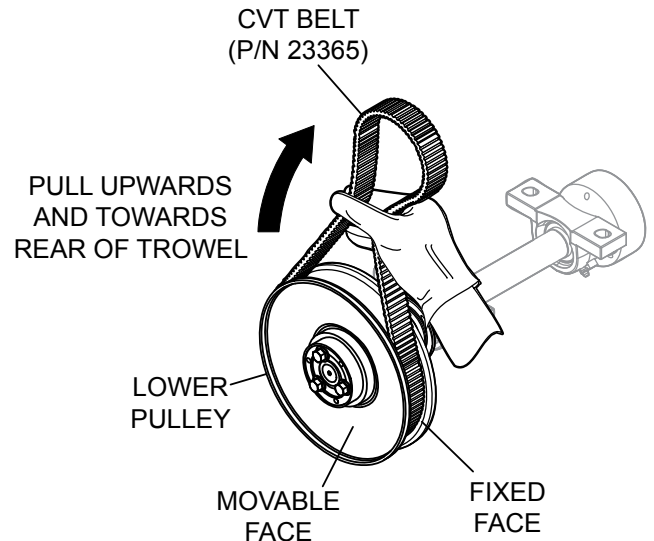

Figure 19. Holding Lower Pulley Open

NOTICE

DO NOT use a pry bar to open the lower pulley grooves. This can cause damage to the lower pulley.

UPPER PULLEY BELT INSTALLATION

1. While holding the clutch in place, free end of CVT belt into upper pulley grooves.

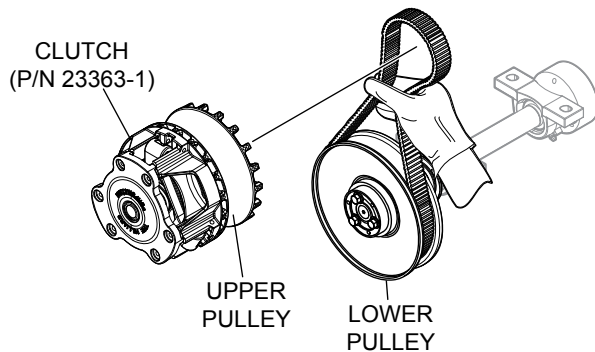

Figure 20. Upper Pulley Belt Installation

2. Once CVT belt has been placed into upper pulley grooves, mount clutch assembly onto stub shaft using 7/16-20 x 6.5" clutch retaining screw
3. Clean the threads of the clutch retaining screw with brake cleaner.
4. Apply primer (Loctite 7649, P/N 32441) then apply Blue Loctite™ #242 (P/N 1477) to clutch retaining screw. See Figure 21.

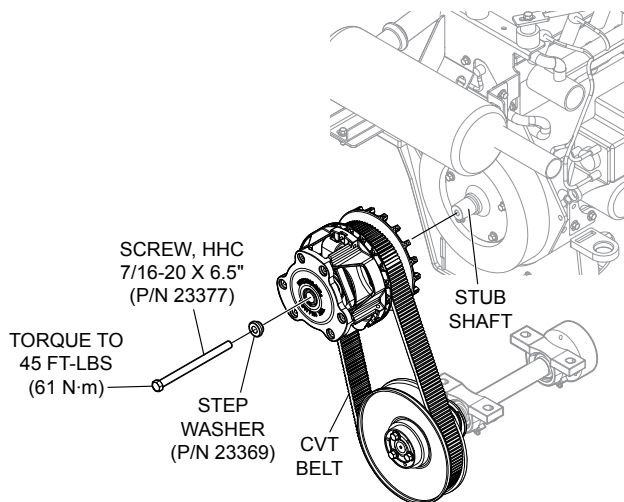

Figure 21. Installing Clutch Assembly

NOTICE

Wedge a 2x4 block of wood between flywheel and trowel frame to prevent flywheel rotation so clutch retaining screw can be fully tightened.

5. Torque clutch retaining screw to 45 ft-lbs (61 N·m).

REASSEMBLY

1. Rotate left-side seat frame back up to vertical position and secure with existing mounting bolts.
2. Secure choke cable to rear engine panel with cable tie.
3. Rotate seat down to operating position.
4. Reinstall fuel tank onto trowel frame using existing mounting hardware.
5. Reconnect fuel lines and electrical connections as referenced in Figure 8. Turn fuel shut-off valve to the **ON** position. If previously drained, refill with fuel.
6. Unlock spider assemblies.
7. Reinstall battery and reconnect battery cables — **RED** to the positive terminal, **BLACK** to the negative terminal.
8. Reinstall side guards (Figure 3).
9. Reinstall right seat frame side panel (Figure 5).
10. Reinstall splash guard (Figure 6).
11. Tighten air intake hose clamp (Figure 5).

HHX CROSS SHAFT/DRIVE PULLEY INSTALLATION

HERE'S HOW TO GET HELP

PLEASE HAVE THE MODEL AND SERIAL
NUMBER ON-HAND WHEN CALLING

UNITED STATES

Multiquip Corporate Office

18910 Wilmington Ave.
Carson, CA 90746
Contact: mq@multiquip.com

Tel. (800) 421-1244
Fax (310) 537-3927

Service Department

800-421-1244
310-537-3700

Fax: 310-537-4259

Technical Assistance

800-478-1244

Fax: 310-943-2238

MQ Parts Department

800-427-1244
310-537-3700

Fax: 800-672-7877
Fax: 310-637-3284

Warranty Department

800-421-1244
310-537-3700

Fax: 310-943-2249

CANADA

Multiquip

4110 Industriel Boul.
Laval, Quebec, Canada H7L 6V3
Contact: jmartin@multiquip.com

Tel: (450) 625-2244
Tel: (877) 963-4411
Fax: (450) 625-8664

UNITED KINGDOM

Multiquip (UK) Limited Head Office

Unit 2, Northpoint Industrial Estate,
Globe Lane,
Dukinfield, Cheshire SK16 4UJ
Contact: sales@multiquip.co.uk

Tel: 0161 339 2223
Fax: 0161 339 3226

© COPYRIGHT 2014, MULTIQUIP INC.

Multiquip Inc, the MQ logo are registered trademarks of Multiquip Inc. and may not be used, reproduced, or altered without written permission. All other trademarks are the property of their respective owners and used with permission.

This manual MUST accompany the equipment at all times. This manual is considered a permanent part of the equipment and should remain with the unit if resold.

The information and specifications included in this publication were in effect at the time of approval for printing. Illustrations, descriptions, references and technical data contained in this manual are for guidance only and may not be considered as binding. Multiquip Inc. reserves the right to discontinue or change specifications, design or the information published in this publication at any time without notice and without incurring any obligations.

Your Local Dealer is:

